

# IBC-400

## INTELLIGENT STEP MOTOR CONTROLLER



### OVERVIEW

The IBC-400 intelligent motion controller is a complete indexing "sub-system" for operating step motors. Packaged in a protective, compact enclosure it employs multiple state-of-the-art embedded processors that provide simple to very complex motion control functions, such as:

- Serial communication to the network
- Generating step and direction signals
- Program storage and execution
- Parameter input, execute and storage
- User input, output, go and stop
- Analog "joystick" control (optional)
- Encoder feedback (optional)

A convenient (RJ45) connection is used for communications with a "host" PC. Commands from the host execute either as they are sent, or are directed into the non-volatile memory storage where pulsing the GO input triggers execution.

A 15 pin "D" connector provides signals for use with any step motor or servo motor driver that accepts step and direction input. These signals can be sent to multiple drivers from one IBC-400.

### BLOCK DIAGRAM

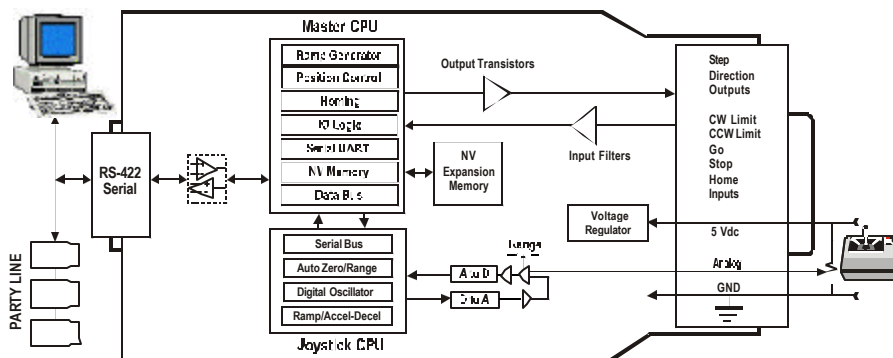

### FEATURES

- **NV Ram for stand alone operation**
- **Multiple control from one COM port**
- **Speeds to over 60,000 steps/second**
- **48 powerful motion commands**
- **Step and direction outputs**
- **Pulse or square wave step output**
- **Limit and home inputs**
- **Go and soft stop inputs**
- **User input ports**
- **1/2 amp output ports**
- **Compact enclosure- 1.7 x 0.8 x 3.9 in.**
- **Industry standard connectors**
- **Optional analog "joystick" input**
- **Optional encoder feedback**

### SERIAL INTERFACE (JI)

The IBC-400 has full duplex, RS-422 party line communications. The 4-wire interface implements a differential transmission and receiver pair. This type of operation provides a high degree of reliability in noisy environments. Each IBC-400 connects to the host terminal and acts as a "listener," awaiting a single character representing its unique "name." On receipt of the name, the addressed axis starts the tri-state differential transmitter.

RS-232 protocol is also available for single axis applications. Direct connection to a hand held terminal is also possible.

### CONTROL SIGNALS

A high density DB-15 connector provides all input and output functions. Inputs are buffered through comparators, capable of withstanding 30 volts. Buffered output signals can sink in excess of 0.5A @ 40 volts, non inductive.

### Signals

Pin	Name	Type
1	Gnd	Logic Gnd
2	VCC	5V Power In
3	Step Out	Output Pulse
4	Direction Out	Output Level
5	Mvg Out	Output Status
6	SS In	Soft Stop
7	Go	Go Input
8	Home	Home Input
9	Limit A	Stop Motion CW
10	Limit B	Stop Motion CCW
11	Port 1	User Input Port
12	Port 2	User Input Port
13	Port 3	User Input Port
14	Port 4	User Output Port
15	Analog	Analog Input

**ANALOG JOYSTICK INTERFACE**

The analog joystick interface adds yet another dimension of motion control possibilities by providing the capability of speed that is proportional to the input voltage. Features include:

- A digitized analog input
- A “dead-zone” that is applied before stepping starts
- Stepping that starts at a specified rate
- Speed, with acceleration setting, increases as voltage increases
- Speed, with deceleration setting, decreases as voltage decreases
- A maximum speed setting
- An auto-zero command that can remove any offset
- Uni-directional or bi-directional modes of operation

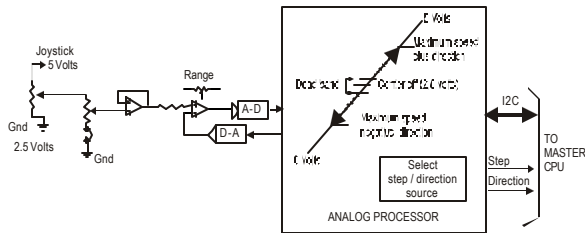

Integral ramping prevents motor “stalls” that could be caused by abrupt input changes. When the “Joystick” mode is selected, there is a separate set of parameters governing speeds and acceleration/deceleration slope.

**COMMAND SUMMARY**

ASCII	Description	ASCII	Description
^C	Software Reset	Q	Query Program
^N	Name Controller	R	Index to Position
^P	Party Line Mode	S	Store Parameters
ESC	Abort/Terminate	T	Trip Point
+	CW Index	V	Slew Speed
-	CCW Index	W	Wait
@	Soft Stop	X	Examine Parameters
[	Read NV Memory	X1	Examine (Analog)
]	Read Limits	Z	Display Position
\	Write to NV Memory	g	Branch to Location
^	Read Moving Bit	i	Special Trip
A	Read/Write User Ports	j	Jump 1
C	Erase Memory	k	Special Trip
D	Divide Steps	l	Set Options
E	Settle Delay	m	Analog Joystick
F	Find Home	u	Print Character
G	Go	1	Auto Calibrate
I	Initial Velocity	3	Dead Zone
J	Jump	4	Accel/Decel Analog
K	Ramp Slope	5	Start Speed
L	Loop on Port	6	Top Speed
M	Move with Ramping	7	Hysteresis
O	Set Origin	8	Divider
P	Program Mode	9	Read Voltage

**ENCODER FEEDBACK**

The IBC-400E includes a quadrature decoder circuit with filtering. This design produces a 4X output. With a quality disc and properly phased encoder, this 4X signal will be accurate to better than 1/2 count. A 500-line encoder mounted to the rear of a stepper motor will generate 2,000 counts per revolution.

In addition to the two channel inputs, index pulse homing is possible. New features with the IBC-400E include provision for battery backup to prevent position loss and operation with almost any resolution encoder.

Features include:

- Use with 50-1024 line (CPR) encoders
- Monitor for stall condition during index
- Retry index “n” times upon stall detect
- Position maintenance mode with deadband
- Battery backup input to keep position registers

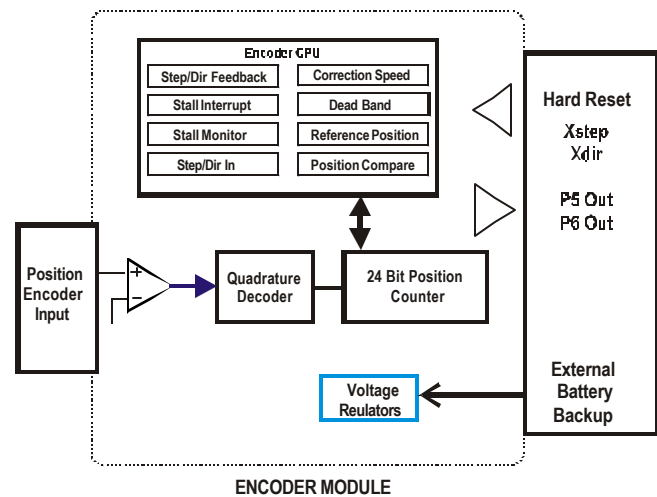

The encoder CPU receives the parameter information: encoder resolution, microstep resolution, deadband size, allowed lag, and hunt speeds. On receipt of an index command, the CPU calculates a number for the “step index” and stall monitoring is started, by loading the retry counter. The encoder CPU counts the master (IBC-400) CPU motor steps and samples the actual encoder position periodically (25 times per revolution). If the distance traveled is less than the specified lag distance, then a stall condition is triggered. The encoder CPU decrements the stall-retry counter and notifies the master CPU of the stall event for correction.

**ENCODER COMMANDS**

ASCII	Description	ASCII	Description
d	Set Deadband	r	Set Stall Retry Count
e	Enable Encoder	s	Stall Detect
h	Set Resolution	v	Hunt Velocity
o	Force Position	z	Read Enc. Position

**SPECIFICATIONS**

**Power Supplies**

Logic Supply .....4.7 - 5.5Vdc

**Controller**

Step Rate Range.....0.16 - 65,535 SPS

Maximum Speed (D=0) .....100,000 SPS

Non-Volatile Memory.....512+2048 Bytes

Communication.....Full Duplex RS-422, 9600 Baud

Maximum Networked.....32 Axes-4,000 Feet

**I/O (Standard)**

Digital Inputs (3).....Limits (2), Home, Go, Stop

Outputs.....Moving (1), User Defined (1)

**Joystick**

Analog Joystick Input (1).....0-12V or 2.5±5V

Analog Speed Range.....0.12 - 15,000 SPS

**Signal Specifications**

Standard	Min	Typ	Max	Units
I.O. Supply VIO (internal)		4.7		Vdc
Digital Threshold		1.6		Vdc
Digital Inputs (Vin)	-0.7		28	Vdc
Input Current (Sinking)		0.5	2.8	mA
Output (Ports 4, 5, 6, Mvg)				
Output Voltage			36	Vdc
Output Current			0.5	Amp

**RECOMMENDED ACCESSORIES**

**SIN-11 Serial Adapter**

The SIN-11 is an intelligent serial line converter that simplifies software development and improves overall communication performance. It is shown here connected to the IBC-400.



The SIN-11 eliminates the need for special echoed character software so it can be used in Windows applications where either the machine or software is slow and/or the operating system prevents direct programming of input or output instructions. The SIN-11 can also be interfaced to a USB adapter.

**BLC-400 Expander Board**

The BLC-400 is a low cost accessory that provides a convenient mounting option for the IBC-400 and two 8 pin terminal strips to interface the control signals and VCC. It is especially suitable for small production runs or prototype designs. The BLC-400 includes a 5 volt regulator to power the IBC-400 and SIN-11 serial adapter. Voltage input range is 8 - 28Vdc.

**DIMENSIONS**

